



AMC-SCHOU Cylindrical grinders



*The Benefits of Precision*

## Company history and Profile

AMC-SCHOU A/S was established more than 50 years ago and has always been involved in precision grinding.

In 1981, AMC was acquired by Højbjerg Maskinfabrik, the HMF Group, which is the market leader in Scandinavia within the manufacturing of cranes, trailers and truck loaders and employs a total workforce of more than 750.

Today, AMC-SCHOU A/S is the result of a merger between three independent Danish-based companies - all manufacturers of crankshaft grinders and suppliers of machine tools for the engine reconditioning industry.

In 1998, AMC-SCHOU A/S moved to new, purpose-built, 9,000 square metre premises in Galten, 20 kilometres west of Aarhus.

Over the years, AMC-SCHOU A/S has delivered in excess of 16,000 automotive reconditioning machines to more than 100 countries worldwide, and the company is renowned for its high-quality products throughout the industry.

Three decades ago, AMC-SCHOU A/S developed the first roll grinder based on the experience achieved from the crankshaft grinder program, and the company has successfully continued to develop this line of machinery.

Our aim is to develop and improve our range of cylindrical grinders continuously, and we look forward to welcoming you as an AMC-SCHOU A/S customer.



The HMF loader named Thor is the largest crane in the program with its 72 t/m. It is an application of the most recent technology as regards control and safety. It has high lifting capacity and long out-reach.



AMC-SCHOU A/S is manufacturing high-end machinery for the engine reconditioning industry. Machines are still running even 50 years after installation and spare parts are still supplied. The AMC-SCHOU A/S "red-line machines" are high quality.



The headquarter facilities in Galten, Denmark, are purpose-built in 1998. At the facility machines are assembled and tested.

## INDEX

## page

Company history and profile	2
Landing gear grinding	4 - 5
It is about people	6 - 7
Steel grinding	8 - 9
AMC-SCHOU A/S worldwide and after sales service	10 - 11
Rubber roller grinding	12 - 13
Extra equipment	14
Models	15

As we are continuously improving our machines, descriptions and illustrations are not binding in detail.



Everyone wants a safe flight!





Swivelable CNC B-axis for automatic positioning of the wheel head at any desired angle.



...by manufacturing the right machinery.

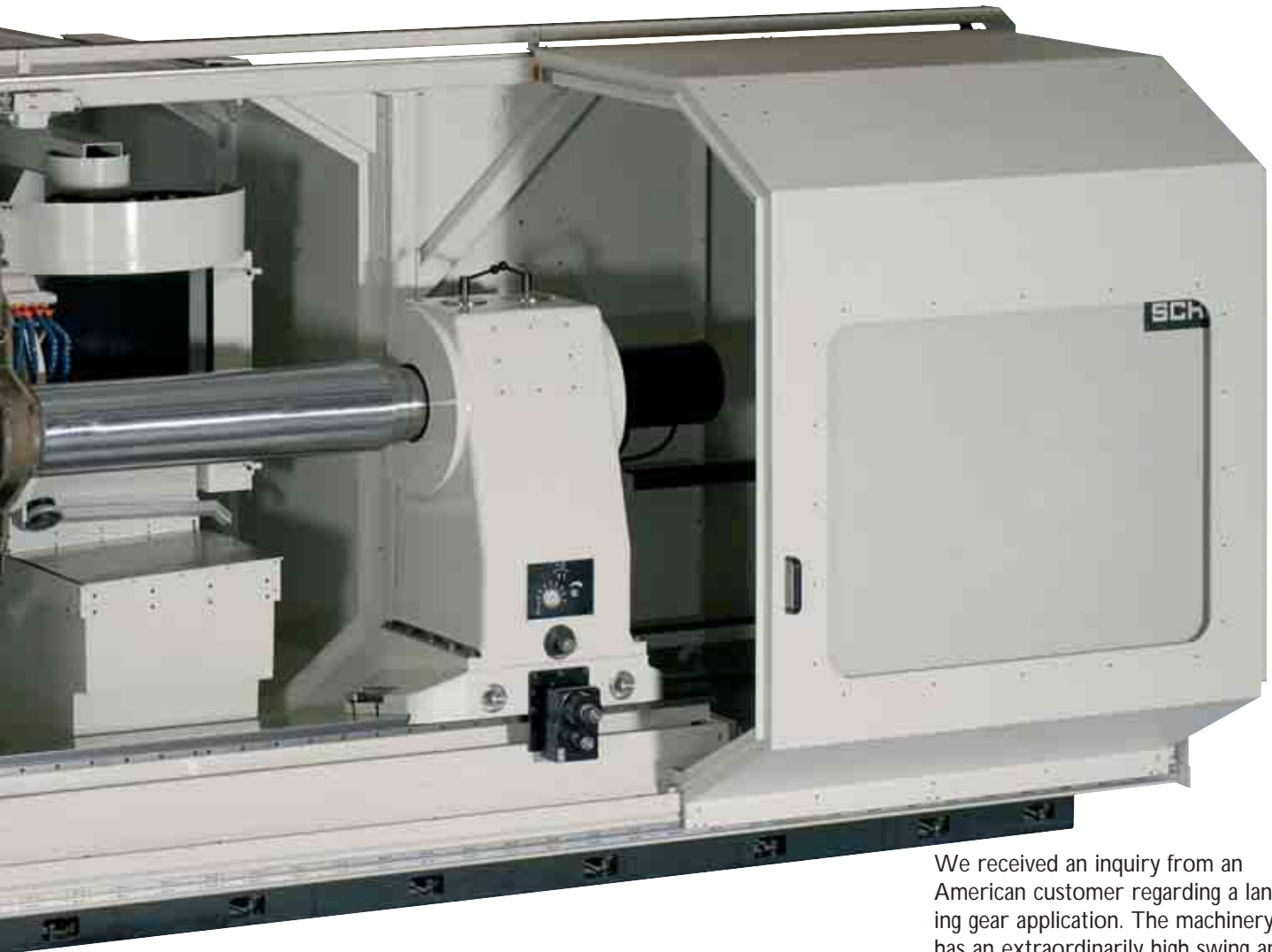

We received an inquiry from an American customer regarding a landing gear application. The machinery has an extraordinarily high swing and is equipped with two grinding wheels mounted on a B-axis. Other features include measuring probes, airlifted head- and tailstocks, auto balancing and full enclosure.



Electrical cabinet.

The machine can be equipped with acoustic sensors to prevent unforeseen and unintended movements and actions causing collisions with the work-piece, dresser, headstock, tailstock etc.

We use SKF and Rexroth high-precision ball screws for X- and Z-axis ensuring smooth, accurate and trouble-free movements of the antifriction covered table and wheel slide.

- SKF bearings in heavy duty design in head- and tailstock ensuring smooth and trouble-free rotation of even extra heavy work-pieces.

- The Weiss motor spindles ensure trouble-free operation and long operating life.

A variety of measuring devices such as probes and in-process measuring equipment can be mounted on the machines depending on end user requirements.



**TECHNICAL  
SPECIFICATIONS**

**R-2000 CNC B**

Max. distance between chucks	mm	2000
	inch	79
Max. swing over table	mm	2000
	inch	79
Max. weight of work-piece	kg	5000
	lbs	11023
Table speeds	mm/min	1-3000
	inch/min	0.04-118
Headstock spindle speeds, variable	rpm	1-100
Headstock spindle motor	kW	12
	hp	16
Grinding wheel motors	kW	15
	hp	20
X-axis motor	Nm	15
	Ft lbf	11
Z-axis motor	Nm	70
	Ft lbf	52
Tailstock quill	mm	90
	inch	3.5
Max. centre pressure	N	32000
	lbf	7200
Max. grinding wheel diameter	mm	800
	inch	31.5
Max. grinding wheel width	mm	100
	inch	4
Working space (working machine)	mm	8100x4800
	inch	319x189
Height of highest point	mm	3100
	inch	122
Height at work-piece center	mm	1670
	inch	66
Net weight of basic machine	kg	17500
	lbs	38500



Rear view of the machine with the coolant unit.

it's a matter of precision...





## It's about people!

In a working environment, it is important that the staff is highly motivated in their daily work, as this leads to innovative and high-quality products.

We strive to motivate our staff and take pride in manufacturing high-precision machinery.

Critical surfaces on for example head- and tailstock are hand scraped: An efficient high-quality and old manual technique which is carried out in-house.

Measuring equipment is employed in the daily work at the factory. Assembly of high-precision machinery eliminates any compromises.





Our close partnership with SIEMENS ensures that we always use the most recent and up-to-date controls on our CNC machines, like the 840SL, which is currently used on our grinders.

In addition, all our heavy duty machines are equipped with a WEISS spindle. WEISS is also an affiliated SIEMENS company.

SIEMENS Simodrive motors are used for powering the headstock and grinding wheel spindle.

With SIEMENS worldwide service and support, machine breakdowns are quickly dealt with and downtime is kept to a minimum.

Both AMC-SCHOU A/S and our parent company; HMF Group, share machining facilities, thus ensuring efficient communication and compliance with delivery times.

Working in close collaboration with our long time supplier of cast iron, German-based foundry Hulvershorn, who are renowned for their high-grade and high-quality cast iron, we have simplified the design of our machines.

The result is an extremely compact and sturdy machine base with an optimized weight-to-load ratio. This reduces costs and space requirements for the end user.

To further secure the high accuracy which is the trademark of AMC-SCHOU A/S, our machines are designed with a "travelling" table. Together with the solid machine base, it ensures a 100% stable and solid machine, a good surface finish as well as very tight tolerances on the part being ground is obtained.

In-house, we are able to machine huge size items. Our Okuma bridge mill is one of the largest machine centers in Europe and all vital parts are manufactured by highly skilled machinists.



Roll on and keep spinning.



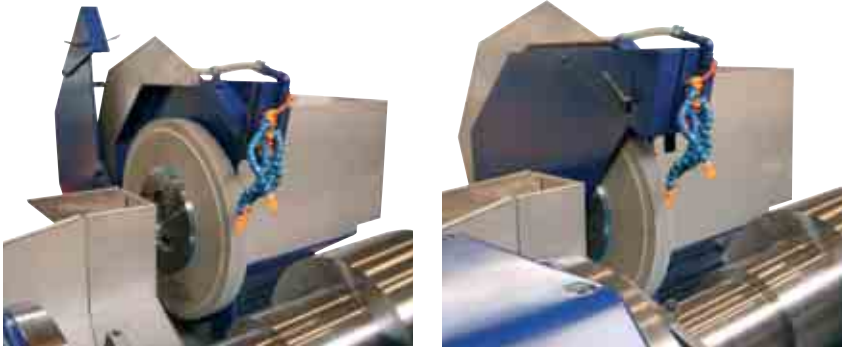
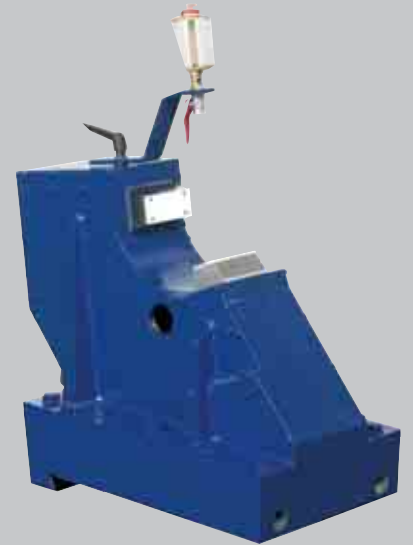

Heavy duty steady rests are essential for heavy loads.

Retractable wheel guard is an option if excessive face grinding is required.





The smallest machine in the program is the R-1800 CNC.



Enclosure in various designs can be fitted on the machines.



At AMC-SCHOU A/S we cooperate with our customers on the final solution to design the most efficient, user-friendly and sturdy machines.

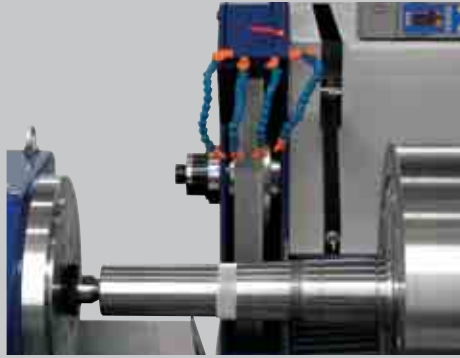

SKF and Deutsche Star Rexroth high-precision ball screws for X- and Z-axis ensure smooth, accurate and trouble-free movement of the antifriction covered table and wheel slide. Heavy duty SKF bearings in head- and tailstock ensure smooth and trouble-free rotation of even extra heavy work-pieces.



AMC-SCHOU A/S manufactures a conventional line of manual and semi-automatic machines capable of grinding work-pieces of up to 4000 mm / 157" in length, with a diameter of 610 mm / 24" and max. work-piece weight of 2 tons / 4408 lbs.

In today's modern manufacturing climate, companies must improve their research and development capacity, invest in high-efficiency machinery and equipment, implement LEAN manufacturing processes and focus on human resources if they are to stay one step ahead of the competition.

The modern steel grinder faces increasing demands for accuracy and surface finish.

New steel grades and alloys are developed at an ever increasing rate. This results in extra pressure on manufacturers in terms of flexibility and frequent changes to grinding parameters.



**TECHNICAL  
SPECIFICATIONS HD**

**R-2000 CNC HD**

**R-4000 CNC HD**

**R-6000 CNC HD**

Max. distance between chucks	mm	2000	4000	6000
	inch	79	157	236
Max. distance between centres	mm	2000	4000	6000
	inch	79	157	236
Max. swing over table	mm	1100	1100	1100
	inch	43	43	43
Max. weight of work-piece between chucks	kg	15000	15000	15000
	lbs	33069	33069	33069
Table speeds	mm/min	1-3000	1-3000	1-3000
	inch/min	0.04-118	0.04-118	0.04-118
Headstock spindle speeds, variable	rpm	2-140	2-140	2-140
Headstock motor	kW	17	17	17
	hp	23	23	23
Grinding wheel motor	kW	37	37	37
	hp	50	50	50
Max. grinding wheel diameter	mm	1000	1000	1000
	inch	40	40	40
Max. grinding wheel width	mm	100	100	100
	inch	4	4	4
Diameter of grinding wheel bore for hub	mm	305	305	305
	inch	12	12	12
Max. tailstock quill	mm	90	90	90
	inch	3.5	3.5	3.5
Working space (working machine)	mm	8700x3500	12500x3500	16500x3500
	inch	343x138	492x138	650x138
Net weight of basic machine	kg	15600	20700	24100
	lbs	34391	45636	53131
Gross weight of basic machine	kg	17600	22700	26500
	lbs	38801	50045	58202

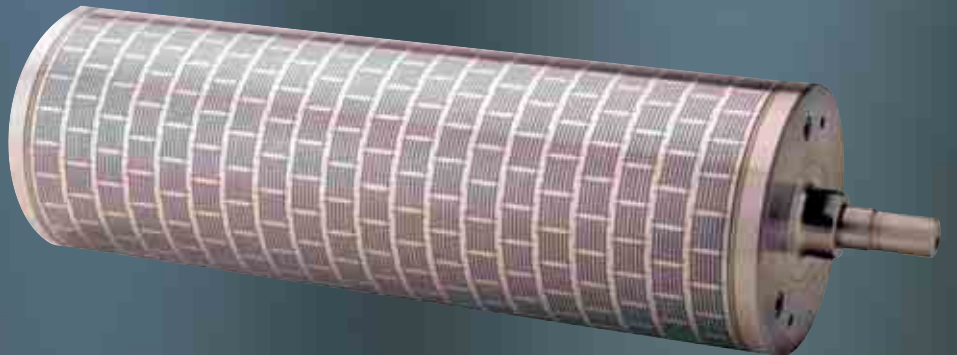

# Customer statements

AMC-SCHOU A/S is renowned for its commitment to servicing all machines - both old and new. This service concept is highly valued by our customers. AMC-SCHOU A/S has an online set-up with UPS which guarantees fast delivery worldwide. Our team of experienced service engineers provides installation, commissioning and training of local machine operators around the world.

“ Furthermore, the machines are powerful and well designed and AMC-SCHOU A/S provides great service and backup.”

ABBA RUBBER INTERNATIONAL  
Bob McDonald, President and CEO,  
California, USA

“ For several years we have been working with CNC cylindrical grinders from AMC-SCHOU A/S. Because of their high-quality grinders and excellent customer service, we are planning to upgrade all our machines to only AMC-SCHOU A/S grinders. We feel AMC-SCHOU A/S provides quality and service at a level that meets our expectations.”

Egberts Rubber bv  
Ben Egberts – Technical Manager  
Almelo, The Netherlands

“ The setting up of work-pieces is very simple and these machines are very easy to work with. And not only that – they are also extremely productive.”

Miller Graphics, Niels Henrik Engstrøm,  
Sunne, Sweden

AMC-SCHOU A/S has more than 6,000 part numbers in stock for immediate delivery. Our machine shop produces a significant amount of our spare parts, minimizing delivery times on non-stock items.

For further information, general specifications, news, updates and local agents – please visit our website [www.amc-schou.com](http://www.amc-schou.com).



“ The CNC control system is great and very flexible. It only took us a short time to learn how to set up our programmes. Now it is very easy to produce rollers with difficult geometries and high-quality surfaces. AMC-SCHOU A/S provides excellent customer service.”

HEFNER GmbH & Co. Gummiwerkfabrik  
Konstantin Luda, Geschäftsführer.  
Gärtringen, Germany

“ We bought all nine cylindrical grinders from AMC-SCHOU A/S. We consider them to be the most productive and accurate cylindrical grinders in the world. We are extremely happy with the service provided by AMC-SCHOU A/S and the machines are working very well.”

Lathia Rubber Mfg. Co. P. Ltd.  
The Lathia Family, Mumbai, India

# The roller industry



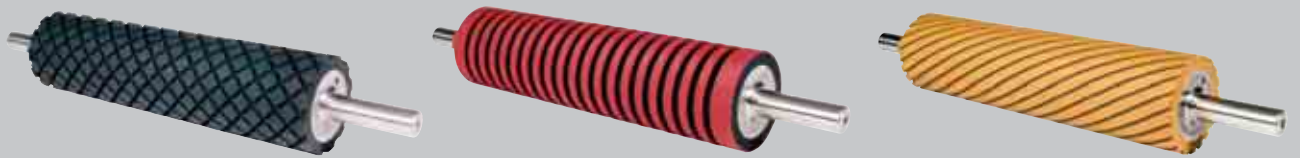

The R-6000 CNC HD with grooving system.

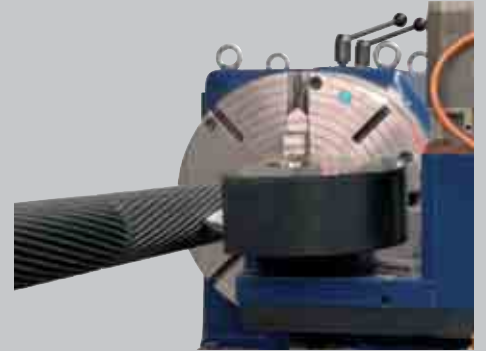

R-1800 CNC is perfect for small rollers.



The number of rollers used in all kinds of industry is almost innumerable. Many everyday products we come across are either fully or partially made using rollers.

Many worn rollers can be reground if new rubber is extruded on. After grinding, some rollers are laser engraved with logos, colours, and cutting dies, etc.

Rollers come in many shapes and sizes, all depending on the end product and the manufacturing process. Many of our customers grind sleeves for the flexographic industry as well.

Our competitive edge in the rubber roller industry is the speed of grinding, amount of stock removal, surface finish and very accurate measurements.

A traditional lathe mounted with a grind post is still commonly used, but these types of machines are slow and inaccurate and the market has begun to demand improved surfaces and higher accuracy.

Our grinder can replace three or four lathes, saving you manpower, space and energy. It also grinds to a higher quality while providing the same output.



### X-2 axis

The X-2 axis is an additional axis that can be installed next to the main grinding wheel on the rear side of the bed.

It is used for an extra grinding wheel for rough grinding or for installation of a polishing unit and is integrated with the CNC controls of the machine.

### Grooving system

The system consists of 4 programmable motors, operated through the Siemens 840SL controller.

Programs for almost every imaginable kind of groove are provided as standard with the machine.

The grooving attachment is placed in front of the machine and the system offers the possibility of grinding and milling.

Milling is performed with variable speed up to 17,500 rpm and using a mounted 12 mm / 1/2" clamping system for various tools.

Grinding is performed using a Siemens digital 5.75 hp servomotor with variable speeds of up to 9,000 rpm, max. grinding wheel 300 mm / 11.8" and max. width 30 mm / 1.2".

The angle is positioned using a Siemens digital servomotor with a brake and enhanced with an Alpha Gear ratio 1:10.

The grooving unit slide moves along linear guides.

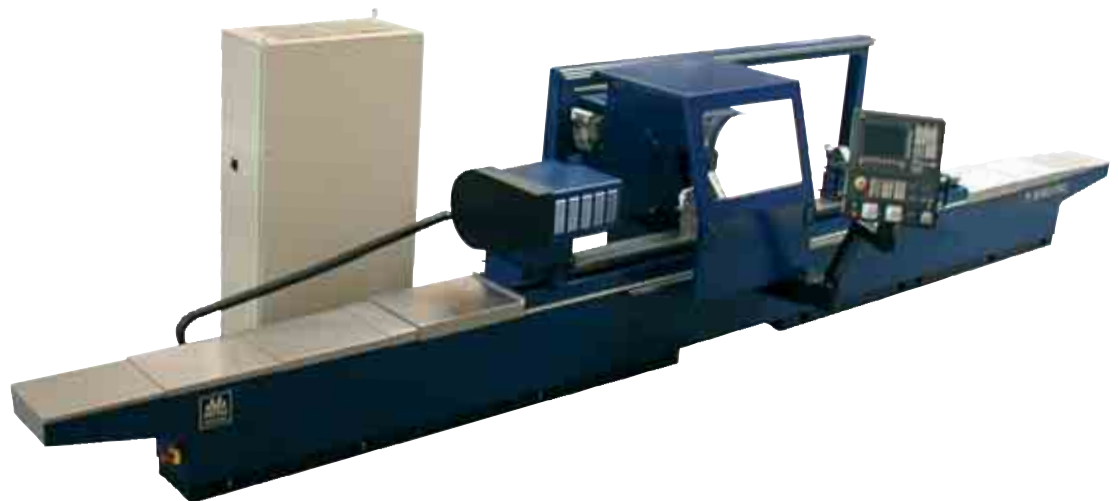

TECHNICAL SPECIFICATIONS		R-1800 CNC	R-2400 CNC	R-3000 CNC	R-4000 CNC
Max. distance between chucks	mm	1850	2450	3050	4050
	inch	73	96	120	160
Max. distance between centres	mm	1800	2400	3000	4050
	inch	71	94	118	160
Max. swing over table	mm	680	680	680	680
	inch	27	27	27	27
Max. weight of work-piece between chucks	kg	2500	2500	2500	2500
	lb	5510	5510	5510	5510
Max. grinding length	mm	1800	2400	3000	4000
	inch	71	94	118	157
Max. grinding diameter with new grinding wheel	mm	610	610	610	610
	inch	24	24	24	24
Table speeds	mm/min	1-4000	1-4000	1-4000	1-4000
	inch/min	0.04-157	0.04-157	0.04-157	0.04-157
Headstock spindle speeds, variable	rpm	2-500	2-500	2-500	2-500
Headstock motor	kW	7	7	7	7
	hp	9.5	9.5	9.5	9.5
Grinding wheel motor	kW	17	17	17	17
	hp	23	23	23	23
Max. grinding wheel diameter	mm	813	813	813	813
	inch	32	32	32	32
Max. grinding wheel width	mm	80	80	80	80
	inch	3.2	3.2	3.2	3.2
Diameter of grinding wheel bore for hub	mm	305	305	305	305
	inch	12	12	12	12
Max. tailstock quill	mm	70	70	70	70
	inch	2.8	2.8	2.8	2.8
Working space (working machine)	mm	6100x2900	7800x2900	9800x2900	12800x2900
	inch	240x114	307x114	386x114	504x114
Net weight of basic machine	kg	4500	5300	6300	7700
	lb	9923	11687	13891	16979
Gross weight of basic machine	kg	5300	6300	7400	9000
	lb	11687	13891	16317	19841

TECHNICAL SPECIFICATIONS		R-1800	R-2400	R-3000	R-4000
Max. distance between chucks	mm	1850	2450	3050	4050
	inch	73	96	120	160
Max. distance between centres	mm	1800	2400	3000	4050
	inch	71	94	118	160
Max. swing over table	mm	680	680	680	680
	inch	27	27	27	27
Max. weight of work-piece between chucks	kg	2500	2500	2500	2500
	lb	5510	5510	5510	5510
Max. grinding length	mm	1800	2400	3000	4000
	inch	71	94	118	157
Max. grinding diameter with new grinding wheel	mm	610	610	610	610
	inch	24	24	24	24
Table speeds	mm/min	30-4000	30-4000	30-4000	30-4000
	inch/min	1.2-157	1.2-157	1.2-157	1.2-157
Headstock spindle speeds, variable	rpm	5-500	5-500	5-500	5-500
Headstock motor	kW	7	7	7	7
	hp	9.5	9.5	9.5	9.5
Grinding wheel motor	kW	15	15	15	15
	hp	20	20	20	20
New grinding wheel diameter	mm	813	813	813	813
	inch	32	32	32	32
Max. grinding wheel width	mm	80	80	80	80
	inch	3.2	3.2	3.2	3.2
Diameter of grinding wheel bore for hub	mm	305	305	305	305
	inch	12	12	12	12
Max. tailstock quill	mm	70	70	70	70
	inch	2.8	2.8	2.8	2.8
Working space (working machine)	mm	6100x2900	7800x2900	9800x2900	12800x2900
	inch	240x114	307x114	386x114	504x114
Net weight of basic machine	kg	4500	5300	6300	7700
	lb	9923	11687	13891	16979
Gross weight of basic machine	kg	5300	6300	7400	9000
	lb	11687	13891	16317	19841

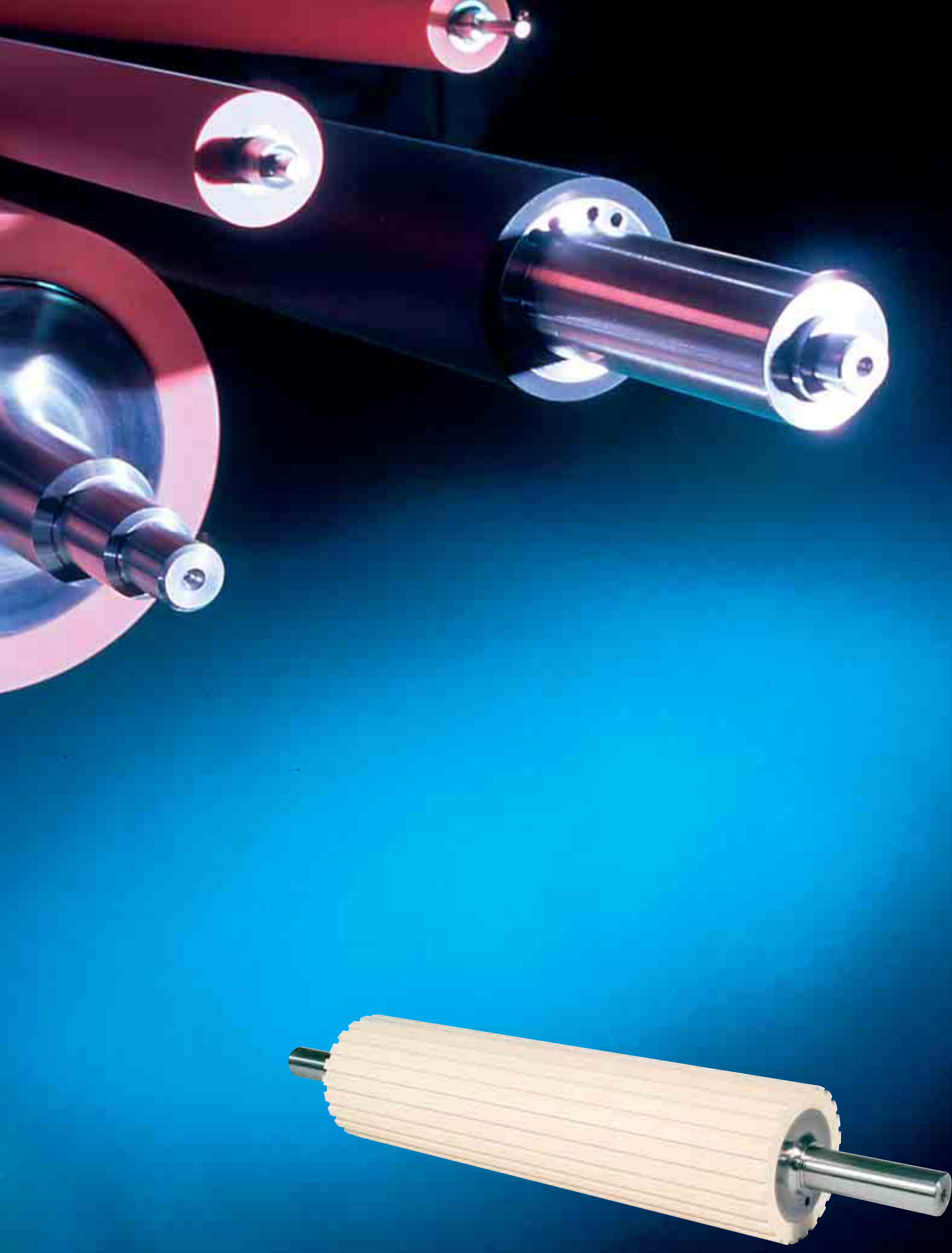

Picture from Teknisk Gummi A/S, Denmark



X-2 axis



Grinding wheel balancing stand



Grinding wheel hub HD Ø305 mm / 12"



Driving dogs with copper shoes



Set-up indicator with quick set dial gauge



Face and side dresser



Automatic balancing system for grinding wheel - incl. display



SCA self-centring chucks with adjustable jaws



Face and side dresser HD version



Coolant unit with band filter and magnetic separator



Heavy duty steady rest capacity Ø50-300 mm



Journal support



Steady rest capacity Ø30-180 mm



Diamond dressing of the wheel

## CURRENT STANDARD MODELS

---

Model	Swing	Grinding length	Weight between centres/chucks
R-1800	680 mm / 26.7"	1800 mm / 71"	800/2500 kg / 1764/5510 lbs
R-2400	680 mm / 26.7"	2400 mm / 94"	800/2500 kg / 1764/5510 lbs
R-3000	680 mm / 26.7"	3000 mm / 118"	800/2500 kg / 1764/5510 lbs
R-4000	680 mm / 26.7"	4000 mm / 157"	800/2500 kg / 1764/5510 lbs
R-1800 CNC	680 mm / 26.7"	1800 mm / 71"	800/2500 kg / 1764/5510 lbs
R-2400 CNC	680 mm / 26.7"	2400 mm / 94"	800/2500 kg / 1764/5510 lbs
R-3000 CNC	680 mm / 26.7"	3000 mm / 118"	800/2500 kg / 1764/5510 lbs
R-4000 CNC	680 mm / 26.7"	4000 mm / 157"	800/2500 kg / 1764/5510 lbs
R-2000 CNC HD	1100 mm / 43.3"	2000 mm / 79"	15000 kg / 33000 lbs
R-4000 CNC HD	1100 mm / 43.3"	4000 mm / 157"	15000 kg / 33000 lbs
R-6000 CNC HD	1100 mm / 43.3"	6000 mm / 236"	15000 kg / 33000 lbs
R-2000 CNC HD B-axis	2000 mm / 79"	2000 mm / 79"	5000 kg / 11023 lbs

---



*The Benefits of Precision*